



Engine Room Console 6

Engine Room Console 6 (ERC6) is engine room simulator with a single desktop hardware console. The modelled main engine model is a conventional, camshaft controlled low speed diesel.



ERC6 has been developed to comply with:

- STCW 2010 Code (with Manila Amendments).
- ISM Code: Section 6 and Section 8.

ERC6 has the type approval certificate issued by EU classification company.

The main educational tasks, which can be accomplished with **ERC6** are listed below:

- Learning typical ship's engine room **operating routines** with the support of the integrated **checklists**.
- Ship's engine room **operation training**. The user will be able to accomplish any operational task starting from pre-prepared or previously saved **exercises**.
- Training in corrective action when faults occur. **Different faults** can be mixed in the run-time or loaded from disk.
- **Standardised and automated assessment** divided into 14 STCW compatible tests. These tests provide an independent and fully objective trainee evaluation.

Engine Room Console 6

ERC6 simulates the low speed diesel engine with a camshaft control. This program is an extended and improved version of the successful VER 4.8 software. VIT system and the exhaust gas analyzer has been implemented as well.

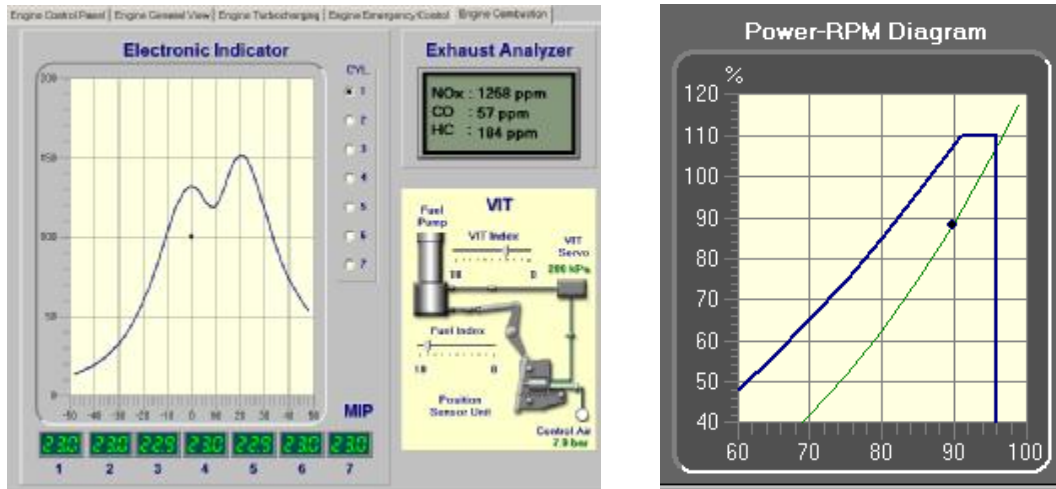

Here is a list of ERC6 main features:

- ERC6 is a **highly realistic simulator with virtual controls** for ship's engine room training which can also be used as a low cost introductory simulator.
- **Mimic diagrams** with active valves, pump status indicators, tank level indicators and selected digital gauges make the system easy to use.
- Multichannel **digitised sound** provides a very realistic ship's engine feel.
- **Synthesized speech** emulates the chief engineers advices
- The **Computer Aided Assessment (CAA)** is fully integrated with the simulator. It includes 3 generic and 14 STCW compatible tests. The **Test Editor** is included, so it is possible to create new, custom tests and to edit the existing tests.
- Possibility of **the exercise recording and replay** with a different speed..
- **Integrated checklists** with a synthesized voice instruction.

Engine Room Console 6

ERC6 simulator model includes the following systems:

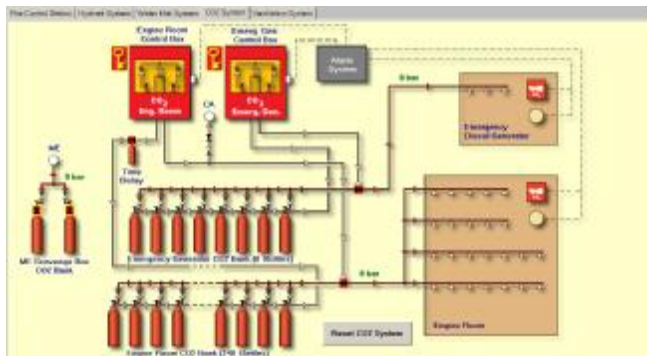
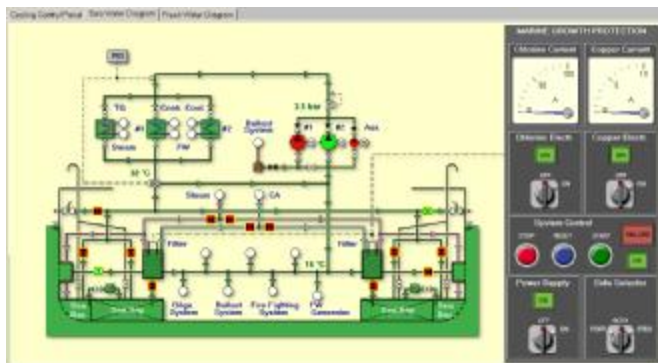
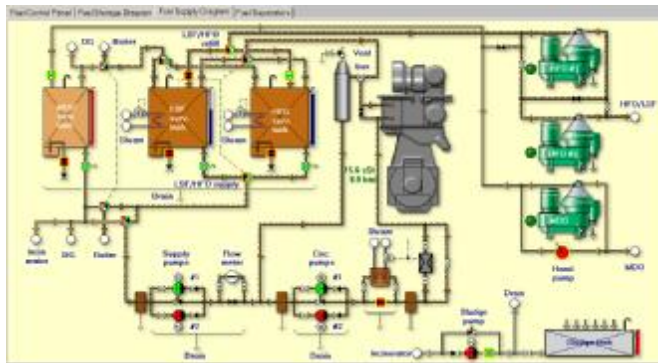

- Main engine (2 stroke, low speed, 7 cylinders, fixed pitch propeller)
- The conventional main engine model with a camshaft and VIT.
- Main engine remote control system (manual from CR, automated from the bridge and the emergency control at the engine side)
- Fuel system (MDO, HFO and **Low Sulphur Fuel**, including storage system and separators).
- Lubricating system (LO circulation and separator, LO storage and stern tube lubricating).
- Cooling system (sea water and fresh water central cooling).
- Compressed air system.
- Sewage treatment plant.
- Sludge and garbage incinerator.
- Steam system (auxiliary boiler, waste heat recovery, superheated steam, consumers).
- Power plant (2 diesel generators, 1 shaft generator, 1 turbo generator and 1 emergency diesel generator, multiple power consumers with separate circuits and bow thruster).
- Bilge system with oily water separator.
- Ballast system.
- Steering gear.
- Refrigerating system.
- Domestic water system
- Air conditioning system
- Simplified own ship model with ship speed modelling.
- **Engine room ventilation system.**
- **Inert gas system.**
- **Turbo pump.**
- **Engine room ventilation system.**
- **Water mist firefighting system.**
- **CO₂ firefighting system.**
- **PID controllers**

ERC6 includes also multiple PID controllers which can be set both: automatically and manually.

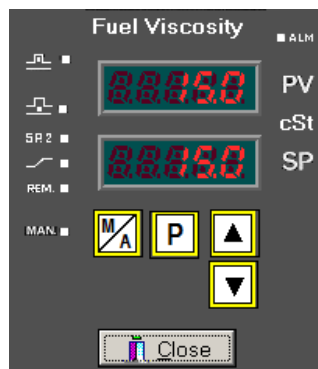

Engine Room Console 6

ERC6 offers different types of user interface:

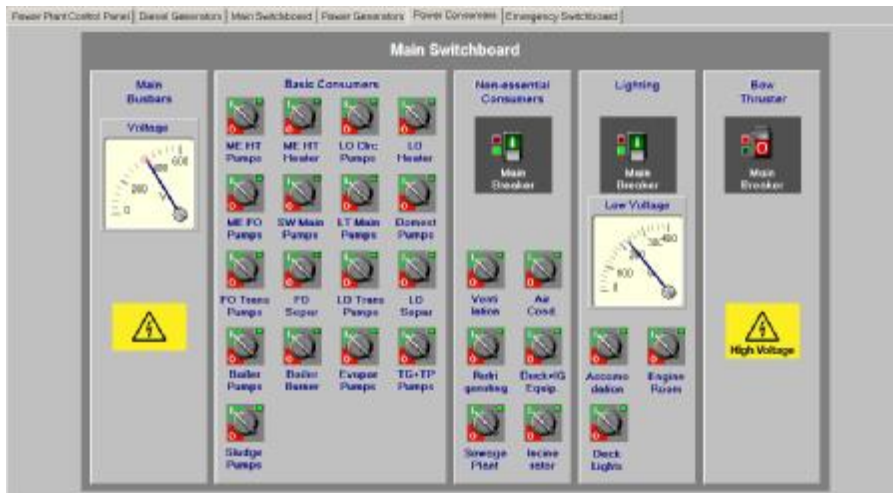

The control panels include very realistic, animated virtual controls like switches, gauges and lamps. The control panels imitate the most important parts of the control room equipment.

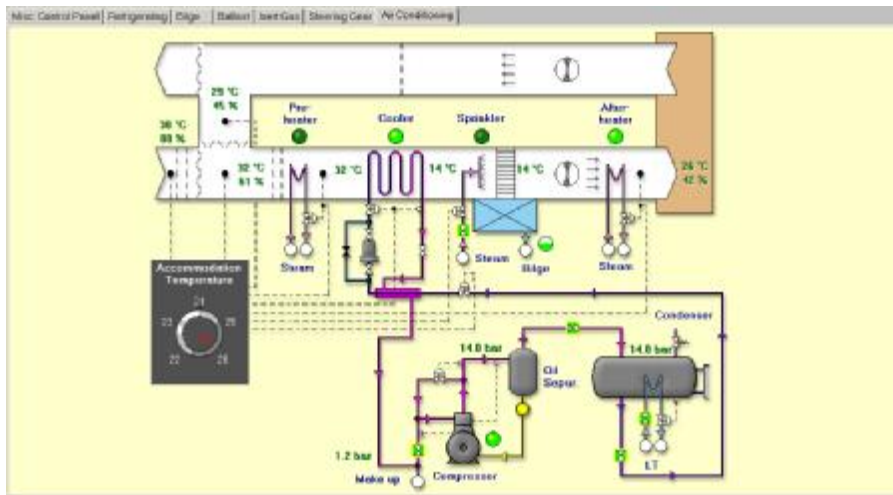

The mimic diagrams present the layout of all vital engine room systems. They include active valves, animated status indicators and tank level gauges.

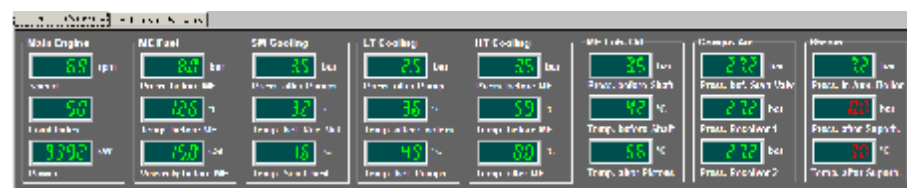

The Parameter Overview shows the most important parameters from the whole engine room combined into media groups.

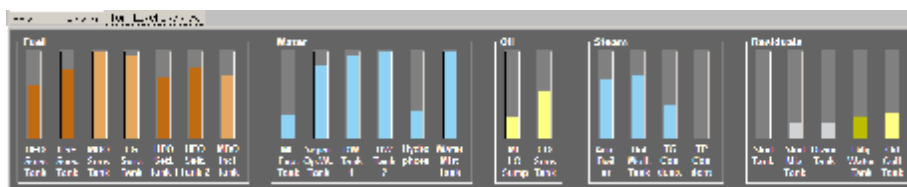

The Tank Level Overview shows the liquid level in the most important tanks from the whole engine room combined into media groups.

Engine Room Console 6

Other examples of **ERC6** features are shown below:

The green **Checklist window** shows instructions relevant to the selected checklist. The appropriate system window will always open when a new checklist step is shown in the checklist window. The control lamp, switch or gauge specified in the checklist step “blinks” in order to make it easier to identify.

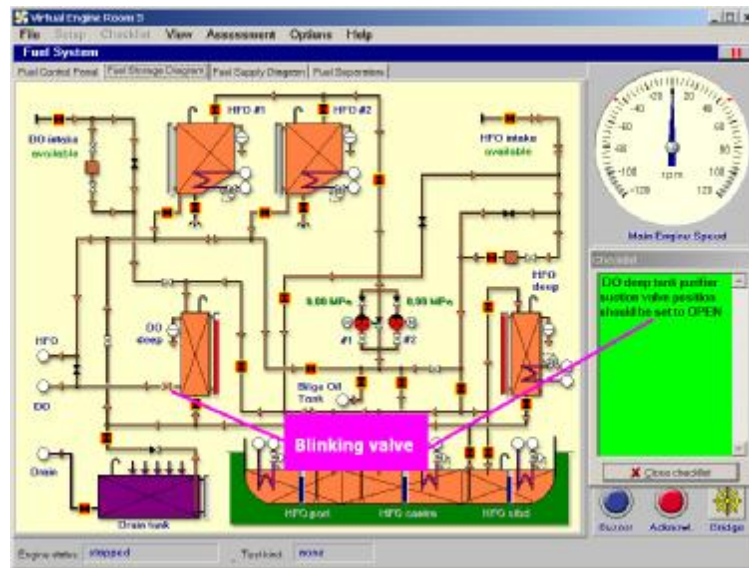

The **Assessment window** includes:

- A full list of errors with related penalty points.
- The total number of penalty points.
- Score in %
- The final results (Passed or failed).

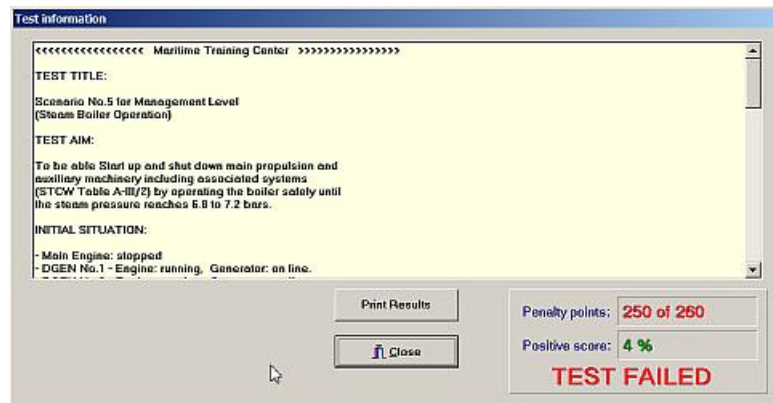

The **Test Editor** enables to create the new custom tests and to edit the existing tests.

It is possible to edit both: the parameter test conditions (limit value plus the logic condition) and the state test conditions (required status). It is possible to assign the penalty points for every test condition.

PARAMETER TEST CONDITIONS

Parameter Name	Units	No	Status	Limit	Value	Penalty	Use it
Diesel Generator No.1 Pinchdown Power	Mvar	211	above	value	0.14	100	yes
Diesel Generator No.2 Pinch Power	MW	214	above	value	0.14	100	yes
Turbo Generator Pinch Power	MW	222	below	value	0.01	100	no
Turbo Generator R.P.M	rpm	258	below	value	700	100	yes

STATE TEST CONDITIONS

State Name	No	Status	Penalty	Use it
Exhaust Boiler Steam Cutler Valve Position	10174	CLOSED	10	yes
Exhaust Boiler Superheated Steam Valve Position	10175	CLOSED	10	yes
Turbo Generator Superheated Steam Inlet Valve Position	10205	CLOSED	10	yes
Turbo Generator Gland Steam Inlet Valve Position	10208	CLOSED	10	yes
Ejector Motive Steam Inlet Valve Position	10211	CLOSED	10	yes
Turbo Generator Condensate Pump Switch Position	10251	OFF	10	yes

For further information please contact: